

EJ200

Eurofighter - Typhoon



The Eurojet Consortium

The EJ200 engine was designed and developed by the European Eurojet Consortium, founded in 1986 through the union of four European companies working in partnership in advanced technological aeroengine development, Rolls-Royce (UK) 33%, MTU (Germany) 33%, Avio (Italy) 21% and ITP (Spain) 13%. Started in 2001, production was slated for 1,400 EJ200 engines, which power the 620 Typhoon fighter aircraft. Besides its installation on the Typhoon, which will also be sold to countries other than the Eurojet partner nations, the EJ200 will be produced for other single- or twin-engine aircraft currently in-service or under development.

The Austrian Air Force elected to adopt the Typhoon as its new fighter; the Consortium delivered all the 32 engines. Eurojet also supports the Austrian fleet ensuring the repair and overhaul of the engines.

The Royal Saudi Air Force signed a contract for 154 engines (of which 13 delivered up to now) and, more recently, an agreement for the first support phase.

Eurojet delivered more than 650 engines to Customers.

EJ200: an engine for extreme performance requirements

Thanks to its two EJ200 engines, which provide a thrust of nearly 20,000 lb, the Typhoon can take off from extremely short runways.

Compared with earlier military engines, the EJ200 enables a significant cost reduction of the weapons system life cycle, also thanks to the Integrated Logistics Support based on advanced software applications of information management.



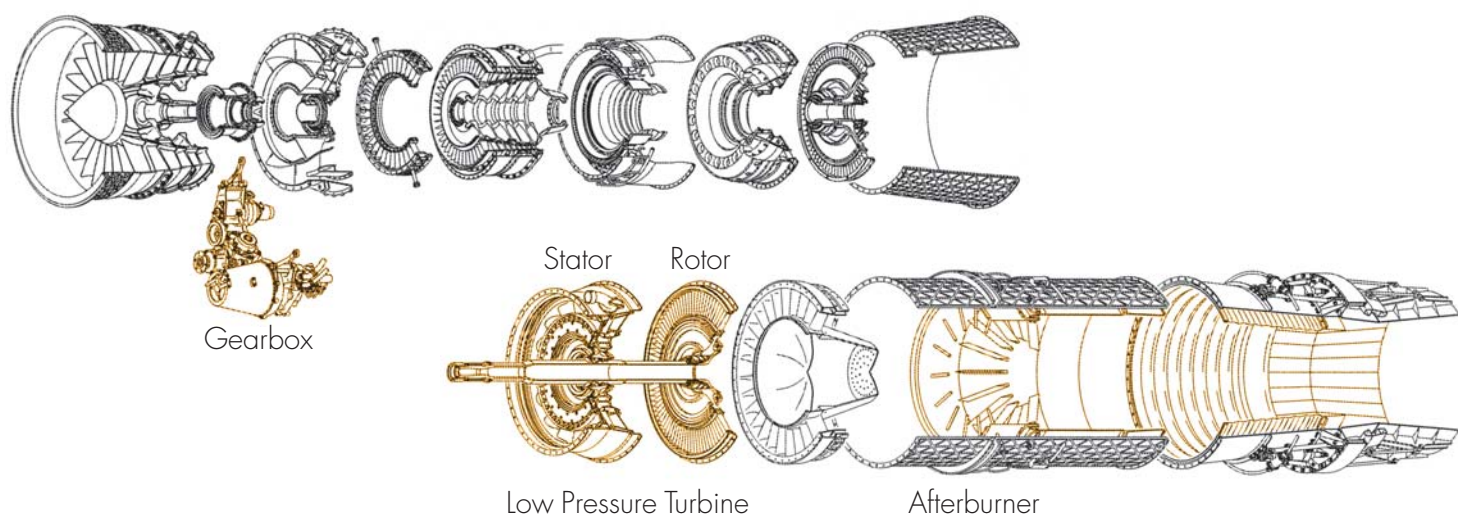

Avio for the EJ200

Avio's high technological know-how is internationally acknowledged, and embraces the entire life cycle of aeroengines, from design and development to assembly and technical and logistics support. As a partner in the EJ200 programme, Avio expanded its capabilities across various system disciplines, among which the development of a significant part of the engine monitoring and control software, and the technical design definition oriented towards reducing life-cycle costs and increased aircraft availability.

This led to significant advances in technologies that confirm Avio's commitment to provide its customers, especially domestic customers, with improved and efficient services. Avio produced the first EJ200 production engine in 2001 for the Italian Air Force (IAF). Up to mid-December 2007, 71 engines had been assembled and delivered to the IAF, completing Tranche 1, and launching Tranche 2. At the end of 2008, Avio delivered the 100th engine. At the end of 2009, the number of Tranche 1 and Tranche 2 engines delivered to the IAF was 120.

Avio-developed components

Accessory Gearbox (AGB)

The main body, which is made from a single casting in magnesium, is connected to the accessories by adapters, which are also made from light alloy. The gearbox drives the engine accessories (combined oil pump, main fuel pump, tank with rotating basket, afterburner pump, air/oil separator and hydraulic pump) through six shafts, while the seventh supplies mechanical power to the gearbox. To reduce the complexity of the engine piping system, the gearbox is equipped with oil and fuel lines created in the casting.

Low-Pressure Turbine (LPT)

The entire system, which is divided into stator and rotor stages (including the low-pressure shaft), is a product of Avio engineering.

To meet the tough requirements in terms of performance, weight and reliability, the turbine was designed with the most up-to-date technologies in materials (last-generation cooled single crystal rotor blades) and mechanical and aerodynamic design. In addition to the stabilisation of high-pressure flow by the stator vane stage, the stator constitutes the rear engine support that holds the two rear bearings of the high- and low-rear shafts.

Afterburner

Avio is responsible for the entire afterburner system downstream from the fuel control valve and light alloy lines, fuel spray control, injectors, flame stabiliser, noise suppresser and heat shields. The geometry of the afterburner was conceived so that it reduces combustion instability, while resisting the extreme operating temperatures, and cools the flaps of the engine exhaust nozzle.

The main function of the afterburner is to mix the cold bypass and main turbine streams. The control system ensures balanced throttle setting and thrust from the afterburner. At equal turbo engine functioning, the afterburner increases engine thrust up to 50% in order to improve aircraft take-off and combat performance.

Other systems

- lubrication system with accessories such as oil pump, tank, sensors and air/oil separator
- engine oil Debris Monitoring System(DMS)
- air system that cools engine components
- stabilisation of internal loads and pressurisation of supports
- hydraulic actuation system of variable geometries: 'inlet guide vanes' of the HP compressor and the exhaust nozzle
- ignition system consisting of a high-power ignition box with dual independent channels to pilot the low-voltage spark plugs

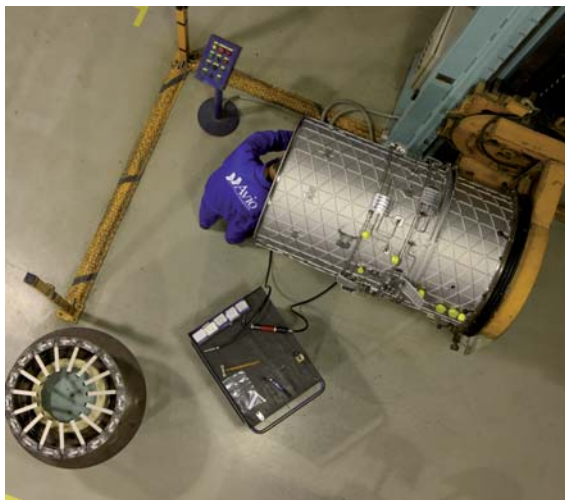

Avio for the Typhoon

The Aircraft Mounted Accessories Drive (AMAD)

Avio's involvement in the Typhoon does not stop at the EJ200. The company is a leader in the DFZI Consortium, which was selected for developing the AMAD. Installed on the drive are the principal electrical and hydraulic accessories that generate the power for flight function and command systems. The partners in the DFZI Consortium are Avio (Italy) 40%, Liebherr (Germany) 30% and Moog (UK) 30%. The Typhoon is equipped with two tandem gearboxes, each of which is connected to the gearbox on the engine that drives it.

The accessories installed on the AMAD are:

- compressed air actuation system (ATS/M)
- Constant Frequency Generator (CFG)
- Hydraulic Pump (HP)
- Direct Current Generator (DCG)

The main body of the box is made from a single casting in magnesium, and the accessories are connected through special adapters in light alloy.

The AMAD functions in two ways:

- 1 starting the main engine (EJ200) on the ground and in-flight, and driving all the other accessories installed
- 2 the transmission of mechanical power from the engine to the connected electrical and hydraulic accessories



Propulsion in the sky, space and sea

Auxiliary Power Unit (APU)

Avio is a participating partner with Honeywell (Germany), CESA (Spain) and Honeywell (UK) in the Consortium responsible for the design and development of the APU on the Typhoon. Within the Consortium, Avio, with a working share of 20%, is responsible for the development of the combustion chambers, external compressor and turbine casings, as well as the assembly and testing of the units that are installed on the aircraft produced for the Air Forces of Italy, Spain and the UK (50%).



Customer support

To ensure the maximum efficiency and operational availability of the weapons system for the entire product life of the EJ200 (30 years); this is the main objective that Avio's Integrated Logistics Support has set itself since the initial phases of the project, and has contributed to guaranteeing the highest availability of the engine system.

In collaboration with its partners, Avio has developed technical manuals and training programmes, taking advantage of the most recent advances in computer-aided learning technologies:

- Interactive Electronic Technical Publications (IETP): conforming to international specifications, these manuals can also be placed on the Internet or intranet
- Computer Based Training (CBT): training for engine technicians through specifically designed instruction content in various formats

of films, photographs, 3D animation, spoken texts and exercises that trainees must complete in order to go on to the next higher course levels

Avio's training centre in Brindisi (Italy) has a theoretical area covered by CBT, and a practical area where On-the-Job-Training (OJT) is carried out. The trainee can apply his theoretical knowledge directly on the engine.

Avio guarantees technical and maintenance support for the EJ200 at the customer's operating base. It also provides comprehensive MRO services for the entire engine and its components at Avio's Centre of Excellence in Brindisi, which handles the service and maintenance of military aircraft engines.

Furthermore, the Brindisi Centre of Excellence is where the repair and overhaul of LH and RH AMAD gearboxes and auxiliary power units is carried out.



Via I Maggio, 99 - 10040 Rivalta di Torino - Torino (Italy) - Tel. +39 011 0082111

www.aviogroup.com